

Wilier TRIESTINA

COLLECTION 2024

THE
ESSENCE
OF CYCLING

Wilier **TRIESTINA**

COLLECTION 2024

This is what we do. Build bikes.

Nothing more than creating a simple object that gets you moving and, when it bears the halberd logo, it becomes an unmistakable emblem of style.

Wilier Triestina's style.

INDEX

6 - 59 **ROAD BIKES**

8	Wilier 0 SLR
16	Filante SLR
32	Granturismo SLR
37	Superleggera
38	Filante SL
44	Wilier 0 SL
45	Garda
47	GTR Team
48	Turbine SLR

E-ROAD BIKES

52	Filante Hybrid
58	Garda Hybrid
59	Cento1 Hybrid

60 - 89 **GRAVEL BIKES**

62	Rave SLR
68	Rave SL
72	Adlar
78	Jena
80	Jaroon
82	Jareen

E-GRAVEL BIKES

84	Adlar Hybrid
87	Adlar Hybrid Flat Bar
88	Jena Hybrid

90 - 113 **MOUNTAIN BIKES**

92	Urta Max SLR
98	Urta SLR
100	Usma SLR
104	110FX
105	101X
105	503X RACE

E-MTB BIKES

106	Urta Hybrid
110	Karga

114	HANDLEBAR GEOMETRIES
116	FRAME GEOMETRIES

RACING ROAD BIKES

PASSION MEETS INGENUITY

The Giro d'Italia, the
Tour de France, the
Grand Classics. Racing
is etched in our history.
The bike: a means for
reaching the goal.





WILIER 0 SLR



NO COMPROMISES

Wilier 0 SLR is the ultra-lightweight racing bike with disc brakes and fully integrated cables.

ULTRA-LIGHTWEIGHT RACING FRAME

A distinctive feature of the Wilier 0 SLR is its lightweight frame: weighing in at under 800 grams in the medium matte black version, Wilier 0 SLR is the most distinguished member of Wilier Triestina's range of super lightweight frames. In fact, in its most advanced configuration, the entire bike tips the scales at a mere 6.5 kg.

TOTAL INTEGRATION

One of the trends most highly appreciated by the public at large is the search for extreme clean lines. Already in 2016, Wilier Triestina started down this road (one of the first bike manufacturers worldwide to do so) with Cento10AIR, inserting the brake and derailleur cables inside the monocoque handlebar which was integrated in the frame.

THE IMPORTANCE OF THE HIGH RATIO BETWEEN RIGIDITY AND FRAME WEIGHT

High STW values are synonymous with performance in carbon frames. Most of the time, we add material to increase a frame's stiffness, thus increasing its weight. But, when weight is to be reduced, stiffness is at risk, and consequently, handling and handling safety as well.

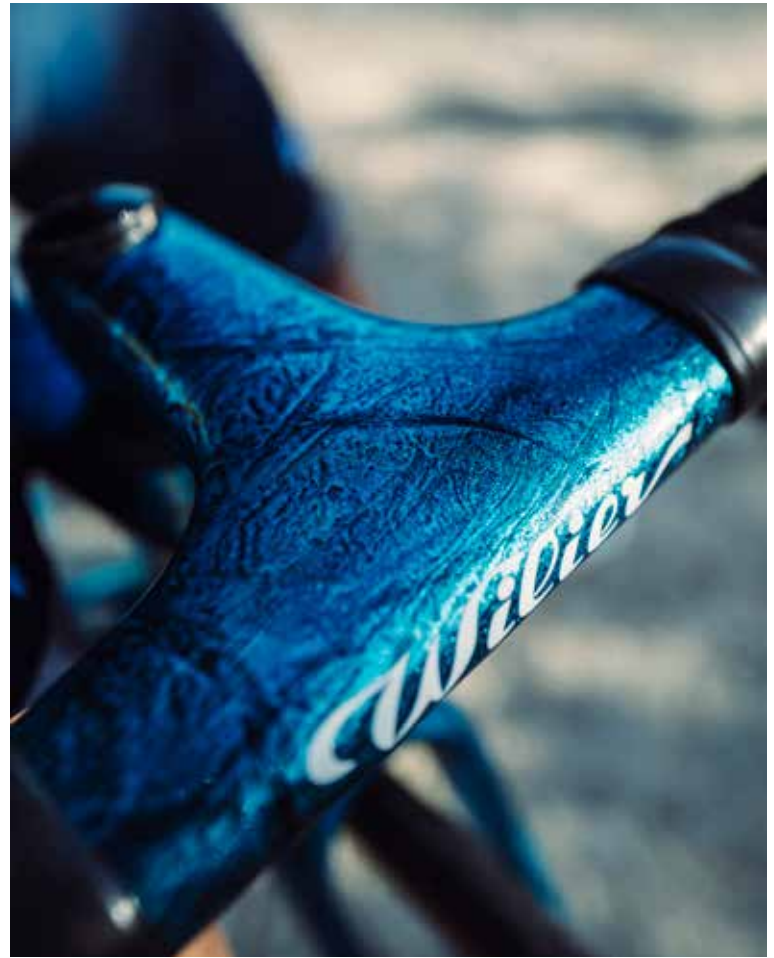

SPEED RELEASE THRU AXLE SYSTEM

Another new feature is the Mavic Speed Release thru axle system that enables the wheel to be quickly removed from the frame. In this way the axle does not need to be totally extracted from the wheel hub. This solution significantly reduces wheel release and insertion time. During races, this solution cuts wheel change times by 7 seconds on average compared to a traditional thru axle system.

BALANCE DESIGN

Six sizes, one feeling. The sections of the tubes of various sizes were designed to maintain consistent rigidity, handling quality and comfort on every frame size. Specifically, during the design phase we created a different section for the main tubes for each size of bicycle in order to increase the frame's torsional stiffness and stability.

ASYMMETRY BECOMES THE SOLUTION

The transmission of power to the rear wheel must not be subjected to dispersions that cause a loss of pedalling efficiency. To meet this demand, we created an asymmetrical rear triangle with the seat stay at a slightly sharper angle than the right. This prevents lateral oscillation due to the force exerted by the cyclist on the chain, thereby turning asymmetry into a solution.





Wilier 0 SLR

ASTANA; GLOSSY - COLOR CODE E15



Frame specifications

Frame CARBON MONOCOQUE HUS MOD + LIQUID CRYSTAL POLYMER - 780 G ± 5%

Fork CARBON MONOCOQUE HUS MOD + LIQUID CRYSTAL POLYMER - 340 G ± 5%

Handlebar ZERO BAR INTEGRATED CARBON - 330 G ± 5%

LIGHTNESS	●●●●●
HANDLING	●●●●●
AERO	●●●●○
COMFORT	●●●●○
PRICE	●●●●●

Frame geometry available on page 116

Full specs, bike weights and prices available at wilier.com



Wilier 0 SLR

RAMATO; GLOSSY - COLOR CODE E12



Frame specifications

Frame CARBON MONOCOQUE HUS MOD + LIQUID CRYSTAL POLYMER - 780 G ± 5%

Fork CARBON MONOCOQUE HUS MOD + LIQUID CRYSTAL POLYMER - 340 G ± 5%

Handlebar ZERO BAR INTEGRATED CARBON - 330 G ± 5%

LIGHTNESS	●●●●●●
HANDLING	●●●●●●
AERO	●●●●○
COMFORT	●●●●○
PRICE	●●●●●●

Frame geometry available on page 116

Full specs, bike weights and prices available at wilier.com

Wilier 0 SLR

IRIDE PETROLEUM; GLOSSY - COLOR CODE E14



Frame specifications

Frame	CARBON MONOCOQUE HUS MOD + LIQUID CRYSTAL POLYMER - 780 G ± 5%
Fork	CARBON MONOCOQUE HUS MOD + LIQUID CRYSTAL POLYMER - 340 G ± 5%
Handlebar	ZERO BAR INTEGRATED CARBON - 330 G ± 5%

 Customization available at [infinitamente.wilier.com](https://www.infinitamente.wilier.com)

LIGHTNESS	●●●●●●
HANDLING	●●●●●●
AERO	●●●●●○
COMFORT	●●●●●○
PRICE	●●●●●●

Frame geometry available on page 116

Full specs, bike weights and prices available at [wilier.com](https://www.wilier.com)

Wilier 0 SLR

VELVET RED; MATT - COLOR CODE E3

LIGHTNESS	●●●●●●●●
HANDLING	●●●●●●●●
AERO	●●●●●●○
COMFORT	●●●●●●○
PRICE	●●●●●●●●



Frame	CARBON MONOCOQUE HUS MOD + LIQUID CRYSTAL POLYMER - 780 G ± 5%
Fork	CARBON MONOCOQUE HUS MOD + LIQUID CRYSTAL POLYMER - 340 G ± 5%
Handlebar	ZERO BAR INTEGRATED CARBON - 330 G ± 5%

 Customization available at [infinitamente.wilier.com](https://www.infinitamente.wilier.com)

Wilier 0 SLR

BLACK, GREY; GLOSSY - COLOR CODE E13

LIGHTNESS	●●●●●●●●
HANDLING	●●●●●●●●
AERO	●●●●●●○
COMFORT	●●●●●●○
PRICE	●●●●●●●●



Frame	CARBON MONOCOQUE HUS MOD + LIQUID CRYSTAL POLYMER - 780 G ± 5%
Fork	CARBON MONOCOQUE HUS MOD + LIQUID CRYSTAL POLYMER - 340 G ± 5%
Handlebar	ZERO BAR INTEGRATED CARBON - 330 G ± 5%

 Customization available at [infinitamente.wilier.com](https://www.infinitamente.wilier.com)



FILANTE SLR

Filante SLR is an extremely lightweight aerodynamic bicycle with a significantly improved stiffness to weight ratio.



AERODYNAMIC

New aerodynamic profiles and solutions that significantly improve aerodynamics. The inside of the front fork has been widened by 7 mm, making it 13.6% wider than the previous. In doing so, we moved the fork blades away from the wheel, reducing turbulence and improving aerodynamics.

LIGHTWEIGHT AND RESPONSIVE

870 gram frame. We have reduced the frame's weight by 11% compared to the previous aerodynamic product in the collection.

The assembled bike with top-of-the-range specifications weighs 6.8 kg. The lower overall weight compared to the exceptional stiffness increases STW by 12.5%.

This improvement is clearly felt with the steering precision and the feeling of safety at high speeds.

240 FITTINGS AVAILABLE

Since the fork steerer tube is no longer bevelled, we can install up to 35 mm of spacers under the handlebar.

By combining frame sizes, handlebar sizes and spacers, we can achieve 240 different fittings, with no overlap between combinations. This doubles with the two available seat posts, with 15 mm or 0 mm setback.

HANDLEBAR AND INTEGRATED CABLES

In addition to being lightweight, (350 grams for the 101x42 size) the new integrated carbon monocoque Filante Bar handlebar houses the brake and derailleur cables, directing them toward the inside of the frame. Its design is very simple, with sinuous and rounded lines for maximum grip ergonomics.

EASY-FIT SPACERS

The spacers between the frame headset and the handlebar are made of a high-stiffness composite material, with a special cavity for the cables.

They are composed of two parts for quick assembly and disassembly without interfering with the cables running from the handlebar to the frame.

BALANCED DESIGN

Six sizes, one feeling. The sections of the tubes of various sizes were designed to maintain consistent rigidity, handling quality and comfort on every frame size.

SPEED RELEASE THRU AXLE SYSTEM

Another new feature is the Mavic Speed Release thru axle system that enables the wheel to be quickly removed from the frame. In this way the axle does not need to be totally extracted from the wheel hub. This solution significantly reduces wheel release and insertion time. During races, this solution cuts wheel change times by 7 seconds on average compared to a traditional thru axle system.





Filante SLR

ASTANA; GLOSSY - COLOR CODE F9



Frame specifications

Frame	CARBON MONOCOQUE HUS MOD + CRYSTAL LIQUID POLYMER - 870 G ± 2%
Fork	CARBON MONOCOQUE HUS MOD + CRYSTAL LIQUID POLYMER - 360 G ± 5%
Handlebar	FILANTE BAR INTEGRATED CARBON - 350 G ± 5%

LIGHTNESS	●●●●●●
HANDLING	●●●●●●
AERO	●●●●●●
COMFORT	●●●●●○
PRICE	●●●●●●

Frame geometry available on page 116

Full specs, bike weights and prices available at wilier.com

WILIER TRIESTINA

FILANTE SLR TDF23



Experience the captivating world of ancient myths with this unique Filante SLR, the hues of white and gold bring this masterpiece to life.

We strive to honor the remarkable achievements of Mark Cavendish, who dedicated himself to becoming the top sprinter in cycling and is now regarded as a legend in the field.

These particular shades carry a profound symbolism, representing purity and strength in their purest form.

Let us unveil the magic that unfolds when colors and mythology unite and join us in celebrating the indomitable spirit of Mark Cavendish, whose perseverance and dedication have propelled him to the pinnacle of success.

Witness the triumph of this extraordinary athlete as he leaves an indelible mark on the world of cycling, inspiring generations to come.

This journey is filled with greatness and accomplishment, where every pedal stroke paints a picture of triumph.



Filante SLR TDF23



TDF23 - COLOR CODE F13



Frame specifications

Frame CARBON MONOCOQUE HUS MOD + CRYSTAL LIQUID POLYMER - 870 G ± 2%

Fork CARBON MONOCOQUE HUS MOD + CRYSTAL LIQUID POLYMER - 360 G ± 5%

Handlebar FILANTE BAR INTEGRATED CARBON - 350 G ± 5%

LIGHTNESS	● ● ● ● ● ●
HANDLING	● ● ● ● ● ●
AERO	● ● ● ● ● ●
COMFORT	● ● ● ● ● ○
PRICE	● ● ● ● ● ●

Frame geometry available on page 116

Full specs, bike weights and prices available at wilier.com



THE ITALIAN ROAD BIKE'S ESSENCE

Witness the breathtaking fusion of Filante SLR and the cycling essence embodied by the iconic Ramato color.

Beyond a mere hue, Ramato encompasses Wilier's unwavering passion for cycling and unrivaled craftsmanship, a classic emblem of Italian heritage.

In perfect harmony with the brand-new Campagnolo Super Record WRL, Filante SLR Ramato epitomizes the very essence of the Italian road bike. So prepare to embark on an extraordinary journey, where tradition intertwines with innovation, resulting in unrivaled performance and timeless elegance.

Unleash the spirit of Italian excellence.
Embrace the mastery of Wilier.



Filante SLR

NEW RAMATO; GLOSSY - COLOR CODE F8



Frame specifications

Frame CARBON MONOCOQUE HUS MOD + CRYSTAL LIQUID POLYMER - 870 G ± 2%

Fork CARBON MONOCOQUE HUS MOD + CRYSTAL LIQUID POLYMER - 360 G ± 5%

Handlebar FILANTE BAR INTEGRATED CARBON - 350 G ± 5%

LIGHTNESS	● ● ● ● ● ●
HANDLING	● ● ● ● ● ●
AERO	● ● ● ● ● ●
COMFORT	● ● ● ● ● ○
PRICE	● ● ● ● ● ●

Frame geometry available on page 116

Full specs, bike weights and prices available at wilier.com



Filante SLR

NEW

CAMPIONE ITALIANO; GLOSSY - COLOR CODE F16



SIMONE VELASCO, CAMPIONE ITALIANO 2023

Filante SLR

NEW

AZZURRO ITALIA; GLOSSY - COLOR CODE F14



Frame specifications

Frame	CARBON MONOCOQUE HUS MOD + CRYSTAL LIQUID POLYMER - 870 G ± 2%
Fork	CARBON MONOCOQUE HUS MOD + CRYSTAL LIQUID POLYMER - 360 G ± 5%
Handlebar	FILANTE BAR INTEGRATED CARBON - 350 G ± 5%



Customization available at [infinitamente.wilier.com](https://www.infinitamente.wilier.com)

LIGHTNESS	●●●●●●
HANDLING	●●●●●●
AERO	●●●●●●
COMFORT	●●●●●○
PRICE	●●●●●●

Frame geometry available on page 116

Full specs, bike weights and prices available at [wilier.com](https://www.wilier.com)

Filante SLR

NEW

MOON GREY; GLOSSY - COLOR CODE F10

LIGHTNESS	●●●●●●●●
HANDLING	●●●●●●●●
AERO	●●●●●●●●
COMFORT	●●●●●○
PRICE	●●●●●●●●



Frame	CARBON MONOCOQUE HUS MOD + CRYSTAL LIQUID POLYMER - 870 G ± 2%
Fork	CARBON MONOCOQUE HUS MOD + CRYSTAL LIQUID POLYMER - 360 G ± 5%
Handlebar	FILANTE BAR INTEGRATED CARBON - 350 G ± 5%

Customization available at [infinitamente.wilier.com](https://www.infinitamente.wilier.com)

Filante SLR

VELVET RED; GLOSSY - COLOR CODE F1

LIGHTNESS	●●●●●●●●
HANDLING	●●●●●●●●
AERO	●●●●●●●●
COMFORT	●●●●●○
PRICE	●●●●●●●●



Frame	CARBON MONOCOQUE HUS MOD + CRYSTAL LIQUID POLYMER - 870 G ± 2%
Fork	CARBON MONOCOQUE HUS MOD + CRYSTAL LIQUID POLYMER - 360 G ± 5%
Handlebar	FILANTE BAR INTEGRATED CARBON - 350 G ± 5%

Customization available at [infinitamente.wilier.com](https://www.infinitamente.wilier.com)

Frame geometry available on page 116
Full specs, bike weights and prices available at [wilier.com](https://www.wilier.com)



GRANTURISMO

SLR

THE PLEASURE OF LONG-DISTANCE RIDES
Granturismo SLR is the racing bike designed to bring out the utmost performance and comfort.

With Granturismo SLR you will be able to travel long distances, minimising postural stress thanks to the special endurance geometries and to the ACTIFLEX 2.0 system, a renewed version of the rear micro-shock absorber developed in 2017 for the Cento10 NDR.

ACTIFLEX 2.0

The heart of Granturismo SLR is the Actiflex 2.0 vibration damping system that enables the rear wheel to obtain up to 5mm in vertical travel.

NEW DESIGN, HIGHER EFFICIENCY

When redesigning Actiflex, one of the main goals was to achieve maximum frame integration, not just for aesthetic purposes but also to make it more functional. In its new position, Actiflex is protected from dirt, mud, sand and rain, offering an ideal solution to allow the four bearings to work easily without having to worry about future maintenance. The double-screw locking system makes disassembling Actiflex 2.0 easy.

TWO TYPES OF ELASTOMER

The rear wheel travel is regulated by an elastomer made of viscoelastic material. In models featuring Shimano Dura Ace Di2 12V, Sram Red AXS and Campagnolo Super Record WRL setups, the elastomer is replaced with a 3D printed conformal lattice structure, a solution that reduces the overall weight of the frame by a further 20g.

RACING COMFORT GEOMETRIES

The frame's geometries play a fundamental role when it comes to endurance bikes.

To guarantee the highest racing and comfort levels, different frame tube proportions must be taken into account. The position is slightly shorter (less reach compared to bikes with traditional racing geometries) and higher (greater stack in comparison to racing geometries).

This combination of reach and stack provides a more comfortable position without the need for spacers between the handlebar stem and the frame.

TIRE CLEARANCE

A wide fork crown improves aerodynamics and offers a generous wheel clearance. Wheels with tires up to a maximum width of 32 mm can be installed on Granturismo SLR, a perfect size for a modern bike like this one bred for endurance.

CARBON MONOCOQUE HANDLEBAR

On Granturismo SLR, we've included the monocoque handlebar, which we usually install on Wilier 0 SLR, our flagship climbing bike. The 0 Bar has a rounded ergonomic grip that's more comfortable than the one on our aero Filante Bar. The spacers, which are the same as those used on the Filante SLR, adapt it perfectly to the frame.

EASY-FIT SPACERS

The spacers between the frame head tube and the handlebar are made of a high-rigidity composite material, with a special cavity for routing the cables. They consist of two parts for quick assembly and disassembly, without interfering with the cables that run from the handlebar to the frame.



Granturismo SLR

FADED RED, WHITE; GLOSSY - COLOR CODE R8



Frame specifications

Frame CARBON MONOCOQUE HUS MOD + LIQUID CRYSTAL POLYMER - 1100 G ± 5%

Fork CARBON MONOCOQUE HUS MOD + LIQUID CRYSTAL POLYMER - 360 G ± 5%

Handlebar ZERO BAR INTEGRATED CARBON - 330 G ± 5%

LIGHTNESS	●●●●○
HANDLING	●●●●●
AERO	●●●●○
COMFORT	●●●●●
PRICE	●●●●○

Frame geometry available on page 116

Full specs, bike weights and prices available at wilier.com

Granturismo SLR

FADED SILVER, EMERALD; GLOSSY - COLOR CODE R9

LIGHTNESS	●●●●●○
HANDLING	●●●●●●
AERO	●●●●●○
COMFORT	●●●●●●
PRICE	●●●●●○



Frame	CARBON MONOCOQUE HUS MOD + LIQUID CRYSTAL POLYMER - 1100 G ± 5%
Fork	CARBON MONOCOQUE HUS MOD + LIQUID CRYSTAL POLYMER - 360 G ± 5%
Handlebar	ZERO BAR INTEGRATED CARBON - 330 G ± 5%

Granturismo SLR

FADED BLACK, GREY; MATT - COLOR CODE R10

LIGHTNESS	●●●●●○
HANDLING	●●●●●●
AERO	●●●●●○
COMFORT	●●●●●●
PRICE	●●●●●○



Frame	CARBON MONOCOQUE HUS MOD + LIQUID CRYSTAL POLYMER - 1100 G ± 5%
Fork	CARBON MONOCOQUE HUS MOD + LIQUID CRYSTAL POLYMER - 360 G ± 5%
Handlebar	ZERO BAR INTEGRATED CARBON - 330 G ± 5%

Superleggera

RAMATO; GLOSSY



Frame specifications

Frame STEEL, COLUMBUS SL - 1690 G ± 5%
 Fork STEEL, COLUMBUS SL - 590 G

LIGHTNESS ●●○○○○
 HANDLING ●●●●○○
 AERO ●●○○○○
 COMFORT ●●●●●●
 PRICE ●●●●○○

Frame geometry available on page 116

Full specs, bike weights and prices available at wilier.com

FILANTE SL



For those of you who are already familiar with our SLR products, when we talk about the SL family, we clearly define the intent behind this type of product: we want to provide a wider audience of cyclists access to bicycles that are very similar to those used by professionals. This means that we scale down the technical characteristics to keep the price at a non-professional level.

Filante SLR is the lightweight and super aerodynamic bicycle used by the Astana professional team, and we wanted to take advantage of the World Tour to attract new customers with a competitively priced bike.



The main difference is the weight of the frame and the standard components. SL's frame will weigh about 150 grams more than Filante SLR.

Basically, the specifications will be similar to those of Wilier 0 SL.

But, instead of an integrated carbon monocoque handlebar, we will have an aluminium stem/handlebar combo, which still includes full cable integration.

Thru-axles will be standard, but without the speed-release functionality available in the SLR version.

The sizes and geometries will be the same as the SLR, so purely a racing style, with three colours



NEW **Filante SL**

SILVER, BLACK; GLOSSY - COLOR CODE F12



Frame specifications

Frame CARBON MONOCOQUE NHU MOD + HIGH IMPACT STRENGTH - 1010 G ± 2%

Fork CARBON MONOCOQUE NHU MOD + HIGH IMPACT STRENGTH - 370 G ± 5%

Handlebar STEMMA SL / BARRA SL

LIGHTNESS	●●●●○
HANDLING	●●●●●
AERO	●●●●●
COMFORT	●●●●○
PRICE	●●●●○

Frame geometry available on page 116

Full specs, bike weights and prices available at wilier.com

NEW

Filante SL

BLACK; GLOSSY - COLOR CODE F11



Frame specifications

Frame	CARBON MONOCOQUE NHU MOD + HIGH IMPACT STRENGTH - 1010 G \pm 2%
Fork	CARBON MONOCOQUE NHU MOD + HIGH IMPACT STRENGTH - 370 G \pm 5%
Handlebar	STEMMA SL / BARRA SL

LIGHTNESS	●●●●●○
HANDLING	●●●●●●
AERO	●●●●●●
COMFORT	●●●●●○
PRICE	●●●●●○

Frame geometry available on page 116

Full specs, bike weights and prices available at wilier.com



Filante SL

RED, BLACK; GLOSSY - COLOR CODE F15



Frame specifications

Frame	CARBON MONOCOQUE NHU MOD + HIGH IMPACT STRENGTH - 1010 G ± 2%
Fork	CARBON MONOCOQUE NHU MOD + HIGH IMPACT STRENGTH - 370 G ± 5%
Handlebar	STEMMA SL / BARRA SL

LIGHTNESS	●●●●○
HANDLING	●●●●●
AERO	●●●●●
COMFORT	●●●●○
PRICE	●●●●○

Frame geometry available on page 116

Full specs, bike weights and prices available at wilier.com

Wilier 0 SL

BLACK, RED; MATT - COLOR CODE E8

LIGHTNESS	●●●●●○
HANDLING	●●●●●●
AERO	●●●●○○
COMFORT	●●●●●○
PRICE	●●●●●○



- Frame CARBON MONOCOQUE NH MOD + HIGH IMPACT STRENGTH - 930 G ± 5%
- Fork CARBON MONOCOQUE NH MOD + HIGH IMPACT STRENGTH - 370 G ± 5%
- Handlebar STEMMA SL / BARRA SL

Wilier 0 SL

GREY, LIGHT BLUE; GLOSSY - COLOR CODE E9

LIGHTNESS	●●●●●○
HANDLING	●●●●●●
AERO	●●●●○○
COMFORT	●●●●●○
PRICE	●●●●●○



- Frame CARBON MONOCOQUE NH MOD + HIGH IMPACT STRENGTH - 930 G ± 5%
- Fork CARBON MONOCOQUE NH MOD + HIGH IMPACT STRENGTH - 370 G ± 5%
- Handlebar STEMMA SL / BARRA SL

Garda

NEW

WHITE, BLACK; GLOSSY - COLOR CODE G40



Frame specifications

Frame	CARBON MONOCOQUE NH MOD - 1150 G ± 5%
Fork	CARBON MONOCOQUE NH MOD - 370 G ± 5%
Handlebar	STEMMA S / BARRA S

LIGHTNESS	●●●●○○
HANDLING	●●●●○○
AERO	●●●●○○
COMFORT	●●●●○○
PRICE	●●●●○○

Frame geometry available on
page 116

Full specs, bike weights and
prices available at wilier.com

Garda

BLACK, RED; MATT - COLOR CODE G36

LIGHTNESS	●●●●○○
HANDLING	●●●●○○
AERO	●●●●○○
COMFORT	●●●●○○
PRICE	●●●●○○



Frame	CARBON MONOCOQUE NH MOD - 1150 G ± 5%
Fork	CARBON MONOCOQUE NH MOD - 370 G ± 5%
Handlebar	STEMMA S / BARRA S

Garda

BLACK, ASTANA BLUE; GLOSSY - COLOR CODE G35

LIGHTNESS	●●●●○○
HANDLING	●●●●○○
AERO	●●●●○○
COMFORT	●●●●○○
PRICE	●●●●○○



Frame	CARBON MONOCOQUE NH MOD - 1150 G ± 5%
Fork	CARBON MONOCOQUE NH MOD - 370 G ± 5%
Handlebar	STEMMA S / BARRA S

GTR Team

GREY, ORANGE; GLOSSY - COLOR CODE G39

LIGHTNESS	●●●○○○
HANDLING	●●●●○○
AERO	●●●○○○
COMFORT	●●●●○○
PRICE	●●○○○○



Frame	CARBON MONOCOQUE 46TON - 1190 G ± 5%
Fork	CARBON MONOCOQUE 46TON - 390 G ± 5%
Brakes	AVAILABLE FOR RIM OR DISC BRAKES

GTR Team

BLACK, WHITE; GLOSSY - COLOR CODE G38

LIGHTNESS	●●●○○○
HANDLING	●●●●○○
AERO	●●●○○○
COMFORT	●●●●○○
PRICE	●●○○○○



Frame	CARBON MONOCOQUE 46TON - 1190 G ± 5%
Fork	CARBON MONOCOQUE 46TON - 390 G ± 5%
Brakes	AVAILABLE FOR RIM OR DISC BRAKES

Frame geometry available on page 116
 Full specs, bike weights and prices available at wilier.com

TURBINE SLR

In 2024 we have revamped our time-trial product used by Astana professionals. It made its début in its prototype version last year at the Giro d'Italia. Now we're presenting it in its official capacity.

Although the frame may look similar to the previous version, its substance is very different. The overall weight has been reduced considerably by about 300 grams. We worked on the frame and the new monocoque handlebar, which has new carbon monocoque extensions.

SLR Turbine's aerodynamic efficiency data are the same as the previous version, but if we consider the product in the real world, its much lower weight significantly increases overall performance in a racing context.

The colour available is this matt and glossy minimal black, with three frames available (with the same geometries as the Turbine of previous collections).





NEW **Turbine SLR**

BLACK, GREY; MATT & GLOSSY - COLOR CODE T13



Frame specifications

Frame	CARBON MONOCOQUE HUS MOD + HIGH IMPACT CARBON - 990 G ± 5%
Fork	CARBON MONOCOQUE 60TON - 390 G
Handlebar	CUSTOM WILIER CARBON BAR

LIGHTNESS	●●●●●●
HANDLING	●●●●○○
AERO	●●●●●●
COMFORT	●●●○○○
PRICE	●●●●●●

Frame geometry available on page 116

Full specs, bike weights and prices available at wilier.com

FILANTE HYBRID

Hybrid Philosophy, Wilier Triestina Performance

It's hard to believe that this bike hides a system providing electric pedal assist. Yet, it does. Filante Hybrid is an electric road bike that integrates the lightest pedal assist system in the world: the new X20 motor by Mahle, a German multinational that is driving technological innovation toward zero-impact mobility. Filante Hybrid was designed with a very specific objective: to help you go faster while minimising strain.





AVANT-GUARD FRAME

Filante Hybrid definitely resembles the Filante SLR, the bike used by Astana Qazaqstan Team professional cyclists. There are no holes in the frame (except for the one required to recharge the battery), and the integrated monocoque carbon handlebar houses the derailleur cables and electrical system controls. The Hybrid also has the same aerodynamic carbon seat post as Filante

BUILT-IN BATTERY AND BATTERY LIFE

The battery integrated in the down tube has a capacity of 236 Wh. An additional bottle-shaped battery can be on the seat post bottle holder to add 171 Wh to the system.

NEW POWER SENSOR

To improve the riding experience, we have introduced a new bottom bracket with torque (power) and frequency sensor. The cyclist (through pedalling, i.e. the power the cyclist delivers) communicates with the motor via the frequency and power sensor. The system reads the "pedalling power" to modulate the assistance delivered to give the cyclist a natural pedalling experience with no jerks, sudden accelerations or loss of assistance. For example, the motor will continue to deliver power smoothly even on steep inclines of over 10%. All of this is necessary as we move toward a cycling experience similar to that of a traditional bicycle.

The power sensor (with the new firmware) also optimises battery consumption, since the power provided by the motor is much more sensitive and proportionate to the power delivered by the cyclist.



NEW MINIATURISED MOTOR

The X20 motor has been miniaturised to the max. It's extremely lightweight (the complete system weighs just 3.6 kg for the X35 and 3.3 kg for the X20), with a modern straight pull spoke pattern and 24 spokes, a perfect match for Wilier Triestina's carbon rims. Mahle's new X20 motor hub delivers 55 Nm of torque, but there's more: the body can be removed easily from the "motor" casing for easy maintenance or replacement. Shimano and SRAM XDR compatible bodies are available.

REAR THRU-AXLE

The wheel that houses the new Mahle X20 motor can be assembled and disassembled quickly, just like on a traditional thru-axle racing bike. In addition to the ease and speed of wheel assembly and disassembly, the system automatically connects to the battery, so there are no more cables to be connected or disconnected by hand. It's all done when you insert the wheel. How? It's easy. The rear dropout has a slider with a built-in electrical connector that ensures the hub positions itself directly in contact with the battery, quickly and with no risk of misalignment.





STANDARD PULSAR ONE

Filante Hybrid comes standard with Pulsar One, a compact and easy-to-use on-board computer with a 2.1" display that updates electrical system data and trip statistics in real time and lets the rider modify the level of pedal assistance if necessary. Pulsar One connects via the ANT+ protocol to the X20 system and to other sensors (cadence sensor, external power sensor and heart rate monitor) and the data can be displayed directly on the screen for a more complete experience.

TOTAL INTEGRATION

The integrated handlebar is carbon monocoque and mimics the aerodynamic design of Filante Bar. However, in the hybrid version, the button and display of the new iWoc, the interface that gives access to the system and changes the pedal assistance mode, are hidden inside the handlebar stem. This unique design improves safety, since cyclists can select one of four power levels (automatic, eco, sport and boost) without having to remove their hands from the top of the handlebar. Mahle has improved iWoc's ergonomics, ease of use and reading compared to the previous version. Cyclists can now see at a glance how much battery capacity remains and which assistance mode is selected.

CLEARANCE & GEOMETRIES

Tire clearance is suitable for a modern road bike and is compatible with rims for tires up to 32 mm wide. Filante Hybrid comes in geometries similar to those of our endurance models. Don't expect an aggressive geometry, although the bike's relaxed look, with a high stack and limited reach, can be deceiving. Six sizes available, from XS to XXL.

Filante Hybrid

NEW

GOLD BLACK; GLOSSY - COLOR CODE Y20



Frame specifications

Frame	CARBON MONOCOQUE HUS-MOD - 1100 G ± 5%
Fork	CARBON MONOCOQUE HUS-MOD - 360 G ± 5%
Handlebar	FILANTE HY INTEGRATED CARBON BAR 350 G ± 5%
Motor	MAHLE X20 & IX250 BATTERY, 236 WH
Display	MAHLE PULSAR ONE

LIGHTNESS	●●●●●●
HANDLING	●●●●●○
AERO	●●●●●●
COMFORT	●●●●●●
PRICE	●●●●●●

Frame geometry available on
page 116

Full specs, bike weights and
prices available at wilier.com

Filante Hybrid

NEW VELVET RED; GLOSSY - COLOR CODE Y19



Frame specifications

Frame	CARBON MONOCOQUE HUS-MOD - 1100 G ± 5%
Fork	CARBON MONOCOQUE HUS-MOD - 360 G ± 5%
Handlebar	FILANTE HY INTEGRATED CARBON BAR 350 G ± 5%
Motor	MAHLE X20 & IX250 BATTERY, 236 WH
Display	MAHLE PULSAR ONE

LIGHTNESS	●●●●●●●●
HANDLING	●●●●●●○
AERO	●●●●●●●●
COMFORT	●●●●●●●●
PRICE	●●●●●●●●

Frame geometry available on page 116

Full specs, bike weights and prices available at wilier.com

Filante Hybrid

SILVER; MATT & GLOSSY - COLOR CODE Y18

LIGHTNESS	●●●●●●●●
HANDLING	●●●●●●○
AERO	●●●●●●●●
COMFORT	●●●●●●●●
PRICE	●●●●●●●●



Frame	CARBON MONOCOQUE HUS-MOD - 1100 G ± 5%
Fork	CARBON MONOCOQUE HUS-MOD - 360 G ± 5%
Handlebar	FILANTE HY INTEGRATED CARBON BAR 350 G ± 5%
Motor	MAHLE X20 & IX250 BATTERY, 236 WH
Display	MAHLE PULSAR ONE

Filante Hybrid

IRIDE BLACK; MATT & GLOSSY - COLOR CODE Y17

LIGHTNESS	●●●●●●●●
HANDLING	●●●●●●○
AERO	●●●●●●●●
COMFORT	●●●●●●●●
PRICE	●●●●●●●●



Frame	CARBON MONOCOQUE HUS-MOD - 1100 G ± 5%
Fork	CARBON MONOCOQUE HUS-MOD - 360 G ± 5%
Handlebar	FILANTE HY INTEGRATED CARBON BAR 350 G ± 5%
Motor	MAHLE X20 & IX250 BATTERY, 236 WH
Display	MAHLE PULSAR ONE

Frame geometry available on page 116
 Full specs, bike weights and prices available at wilier.com

NEW

Garda Hybrid

BLUE, GREY; GLOSSY - COLOR CODE Y22

- LIGHTNESS ●●●●○○
- HANDLING ●●●●○○
- AERO ●●●●○○
- COMFORT ●●●●○○
- PRICE ●●●●○○



Frame CARBON MONOCOQUE NHU MOD + HIGH IMPACT STRENGTH - 1420 G ± 5%
 Fork CARBON MONOCOQUE NHU MOD + HIGH IMPACT STRENGTH - 400 G ± 5%
 Handlebar STEMMA S / BARRA S
Motor MAHLE X35+ & I250 BATTERY, 242 WH

NEW

Garda Hybrid

BLACK, RED; GLOSSY - COLOR CODE Y21

- LIGHTNESS ●●●●○○
- HANDLING ●●●●○○
- AERO ●●●●○○
- COMFORT ●●●●○○
- PRICE ●●●●○○



Frame CARBON MONOCOQUE NHU MOD + HIGH IMPACT STRENGTH - 1420 G ± 5%
 Fork CARBON MONOCOQUE NHU MOD + HIGH IMPACT STRENGTH - 400 G ± 5%
 Handlebar STEMMA S / BARRA S
Motor MAHLE X35+ & I250 BATTERY, 242 WH

Cento1 Hybrid

GREY, BLACK, ORANGE; MATT - COLOR CODE Y13

LIGHTNESS	●●●●○○
HANDLING	●●●●○○
AERO	●●●●○○
COMFORT	●●●●○○
PRICE	●●●●○○



Frame CARBON MONOCOQUE 46TON - 1420 G ± 5%
 Fork CARBON MONOCOQUE 46TON - 400 G ± 5%
Motor MAHLE X35+ & I250 BATTERY, 242 WH

Cento1 Hybrid

BLACK, GREY, RED; GLOSSY - COLOR CODE Y14

LIGHTNESS	●●●●○○
HANDLING	●●●●○○
AERO	●●●●○○
COMFORT	●●●●○○
PRICE	●●●●○○



Frame CARBON MONOCOQUE 46TON - 1420 G ± 5%
 Fork CARBON MONOCOQUE 46TON - 400 G ± 5%
Motor MAHLE X35+ & I250 BATTERY, 242 WH

Frame geometry available on page 116
 Full specs, bike weights and prices available at wilier.com

GRAVEL BIKES

DESTINATION FREEDOM

Breaking the boundaries, discovering a new dimension. Time counts, but only to a point. Dust, mud, white roads. Gravel is cycling that finds its roots.





WILIER TRIESTINA

RAVE SLR

Expect the Unexpected



IVAR SLIK, 2022 UNBOUND GRAVEL CHAMPION

Travelling new roads is not just an attitude. It can also become the target for someone who has been making bicycles for since 1906. With Rave SLR we have set our sights on new horizons, creating a product with two separate souls, perfect for all-road, perfect for gravel, but the same incredible racing inclination. Rave SLR will be a new cycling experience, unexpected for many.

ROAD OR GRAVEL SETUP

Rave SLR colours can be outfitted with top-end road accessories (Shimano Dura Ace Di2, Shimano Ultegra Di2, Sram Force AXS) or high range gravel accessories (Campagnolo Ekar, Shimano GRX or the Sram Force AXS XPLR) with road or gravel tyres up to 42mm.

LIGHTWEIGHT

To create a light frame, we used the same carbon technology mix found in the Filante SLR and the Wilier 0 SLR, just to give an idea.

RESPONSIVE

To create a reactive frame, we've channelled all the experience gained in the use of technopolymers, mixing carbon with special viscoelastic fibres such as Liquid Crystal Polymers. Construction technologies borrowed from those used for the Filante SLR and the Wilier 0 SLR, products that offer an excellent riding quality recognised by the most demanding professional riders.

HIGH PERFORMING

Performance has always been our fixation. And the genesis of the Rave SLR is no different. If we translate performance into concrete aspects, it's about a frame that is light, responsive (stiff where necessary) and features racing geometries.

BALANCED RACING GEOMETRIES

To create a frame with balanced racing geometries, we started with top range road racing references and mixed them with frame parts of endurance and gravel origin: all without distorting the performance target that we set for ourselves at the start of the design phase. A slightly higher stack and a somewhat shorter reach compared to a pure competition bike, combined with the available carbon monocoque handlebars, become the perfect synthesis between high performance and comfort.

HANDLEBAR AND INTEGRATED CABLES

In addition to being lightweight, the 0-Bar and J-Bar monocoque handlebars available on the Rave SLR, house the brake and controls cables, routing them inside the frame. The handlebar and stem combo features an essential design, with sinuous and rounded lines to guarantee the best possible ergonomic grip and provide the Rave SLR with the elegance of Wilier Triestina's high-end products.

EASY-FIT SPACERS

The spacers between the frame head tube and the handlebar are made of a high-rigidity composite material, with a special cavity for routing the cables. They consist of two parts for quick assembly and disassembly, without interfering with the cables that run from the handlebar to the frame.



Rave SLR

NEW

IVAR SLIK / MAAP; MATT - COLOR CODE V7



Frame specifications

Frame CARBON MONOCOQUE HUS-MOD + LIQUID CRYSTAL POLYMER - 950 G ± 5%

Fork CARBON MONOCOQUE HUS-MOD + LIQUID CRYSTAL POLYMER - 415 G ± 5%

Handlebar ZERO BAR INTEGRATED CARBON - 330 G ± 5%

LIGHTNESS	●●●●○
HANDLING	●●●●●
AERO	●●●●○
COMFORT	●●●●○
PRICE	●●●●●

Frame geometry available on page 116

Full specs, bike weights and prices available at wilier.com

Rave SLR

BLACK, GREY; MATT - COLOR CODE V1

- LIGHTNESS ●●●●●○
- HANDLING ●●●●●●
- AERO ●●●●●○
- COMFORT ●●●●●○
- PRICE ●●●●●●



- Frame CARBON MONOCOQUE HUS-MOD + LIQUID CRYSTAL POLYMER - 950 G ± 5%
- Fork CARBON MONOCOQUE HUS-MOD + LIQUID CRYSTAL POLYMER - 415 G ± 5%
- Handlebar J-BAR CARBON MONOCOQUE HANDLEBAR - 390 G ± 5% / ZERO BAR INTEGRATED CARBON - 330 G ± 5%

**ALSO AVAILABLE
WITH ROAD
SETUP**

Rave SLR

SAND, GREEN; MATT - COLOR CODE V2

- LIGHTNESS ●●●●●○
- HANDLING ●●●●●●
- AERO ●●●●●○
- COMFORT ●●●●●○
- PRICE ●●●●●●



- Frame CARBON MONOCOQUE HUS-MOD + LIQUID CRYSTAL POLYMER - 950 G ± 5%
- Fork CARBON MONOCOQUE HUS-MOD + LIQUID CRYSTAL POLYMER - 415 G ± 5%
- Handlebar J-BAR CARBON MONOCOQUE HANDLEBAR - 390 G ± 5% / ZERO BAR INTEGRATED CARBON - 330 G ± 5%

**ALSO AVAILABLE
WITH ROAD
SETUP**

Rave SLR

CAMOUFLAGE, ORANGE; GLOSSY - COLOR CODE V4



Frame specifications

Frame	CARBON MONOCOQUE HUS-MOD + LIQUID CRYSTAL POLYMER - 950 G ± 5%
Fork	CARBON MONOCOQUE HUS-MOD + LIQUID CRYSTAL POLYMER - 415 G ± 5%
Handlebar	J-BAR CARBON MONOCOQUE HANDLEBAR - 390 G ± 5% / ZERO BAR INTEGRATED CARBON - 330 G ± 5%

**ALSO
AVAILABLE
WITH ROAD
SETUP**

LIGHTNESS	●●●●○
HANDLING	●●●●●
AERO	●●●●○
COMFORT	●●●●○
PRICE	●●●●●

Frame geometry available on
page 116

Full specs, bike weights and
prices available at wilier.com

RAVE SL



Like Filante, we are also extending the Rave range, adding a version that we might say is more pop than its SLR sibling.



Remember that Rave SLR is our high-end proposal that's perfect for road/all-road use and for gravel racing Ivar Slik was riding Rave SLR when he won the Unbound Gravel in the United States in 2022.

The main difference is the weight of the frame and the standard components. SL's frame will weigh about 140 grams more than Rave SLR.

But, instead of an integrated carbon monocoque handlebar, we will have an aluminium stem/handlebar combo, which still includes full cable integration.

Rave SL can be fitted with tyres up to 42 mm, with standard thru-axles but without the speed-release functionality available in the SLR version.

Sizes and geometries will be identical to SLR (available in six sizes) with two colours available.

NEW

Rave SL

BROWN, SAND; GLOSSY - COLOR CODE V6



Frame specifications

Frame	CARBON MONOCOQUE NHU-MOD + HIGH IMPACT STRENGTH - 1090 G ± 5%
Fork	CARBON MONOCOQUE NHU-MOD + HIGH IMPACT STRENGTH - 415 G ± 5%
Handlebar	STEMMA SL / BARRA SL

**ALSO AVAILABLE
WITH ROAD
SETUP**

LIGHTNESS	●●●●○○
HANDLING	●●●●●●
AERO	●●●●●○
COMFORT	●●●●●○
PRICE	●●●●○○

*Frame geometry available on
page 116*

*Full specs, bike weights and
prices available at wilier.com*

NEW

Rave SL

BLACK, SILVER; GLOSSY - COLOR CODE V5



Frame specifications

Frame	CARBON MONOCOQUE NHU-MOD + HIGH IMPACT STRENGTH - 1090 G ± 5%
Fork	CARBON MONOCOQUE NHU-MOD + HIGH IMPACT STRENGTH - 415 G ± 5%
Handlebar	STEMMA SL / BARRA SL

**ALSO AVAILABLE
WITH ROAD
SETUP**

LIGHTNESS	●●●●○○
HANDLING	●●●●●●
AERO	●●●●●○
COMFORT	●●●●●○
PRICE	●●●●○○

Frame geometry available on page 116

Full specs, bike weights and prices available at wilier.com

ADLAR

Designed for adventure and bikepacking with a carbon fibre frame. When what really counts is the journey and not the destination.

DARE TO ADVENTURE

When riding, for every cyclist it's a true rite of passage. Your frame of mind at the starting point is never the same as when you arrive. Regardless of how you perceive fatigue, you change within. And so does your view of the world around you. Every adventure is an evolution.

Adlar originates from this tension. A bike as a medium for giving things true meaning and bringing clarity to your vision of the world. An object that together evolves, changes and transforms itself. Isn't this the definition of gravel?





Look at our bikes. Rave SLR: competition. Jena, Jaroon and Jareen: versatile, equipped with different frames in carbon fibre, steel and aluminium, respectively. It was clear that gravel is, and increasingly will be, adventure, a more or less conscious way of capturing its forms and meanings through journey. Ups, downs, chance meetings, hours and hours spent riding in total autonomy, without feeling the rush of time limits. On your own or in company. Adlar is made for bikepacking, for explorers, for bike travellers. The structure of the carbon fibre frame has been reinforced to allow a maximum additional load of 35 kg. This feature has been paired with new designs, a careful study of the geometries and completely integrated cable routing.

SOMETHING DIFFERENT

The frame weighs 1100 g and comes in five sizes: XS, S, M, L, XL. The geometries derive from the mountain bike: the frame triangle develops horizontally, the reach is quite pronounced. This solutions make it possible to use a shorter handlebar stem that works in synergy with the open steering angle (70°). A transformation that translates into better handling and control on the more demanding trails with a fully loaded bike.

READY FOR CHANGE

The generous tyre clearance is made to accommodate any 52 mm (52-622) gravel tyre up to mountainbike tyres measuring 29 x 2.00". The frame has been designed to fit a fork with extra-length blades. This configuration makes it easier to install a suspension fork (40 mm max travel compatible with the 1"1/4 - 1"1/2 conical headset series) without changing the frame overall geometries. Also, the hole on the fork's right stem allows the passage of the dynamo hub cable, if used. Even the 27.2 mm seatpost can be replaced with a dropper post.

INTEGRATED MUDGUARD

All configurations feature exclusively single-drivetrain transmission. This choice has made it possible to free the vertical tube from the derailleur support. In this area the forms have been squeezed to recreate a sort of small integrated mudguard.

FIXING AND LOAD POINTS

The front and back carriers load the weight of the bags onto the thru axles that pass through the frame and fork. This was done to reduce any structural stress on the Adlar. Other fixing points offer stability and the option of installing a third bottle holder or a tool bag under the down tube, in addition to a top tube bag. The accessories kit is completed with the mudguards (sold separately) and a set of 4 quick-hook bags made in partnership with Miss Grape.

MAXIMUM LOAD 35KG





Adlar

LIME, BLACK; GLOSSY - COLOR CODE C7



Frame specifications

Frame CARBON MONOCOQUE NHU MOD - 1190 G ± 5%

Fork CARBON MONOCOQUE NHU MOD - 470 G ± 5%

Handlebar STEMMA S / RITCHEY CORRALITOS

LIGHTNESS	●●●●○
HANDLING	●●●●○
AERO	●●●●○
COMFORT	●●●●●
PRICE	●●●●○

Frame geometry available on page 116

Full specs, bike weights and prices available at wilier.com

NEW

Adlar

GREY, YELLOW; GLOSSY - COLOR CODE C6



Frame specifications

Frame	CARBON MONOCOQUE NHU MOD - 1190 G ± 5%
Fork	CARBON MONOCOQUE NHU MOD - 470 G ± 5%
Handlebar	STEMMA S / RITCHEY CORRALITOS

LIGHTNESS	●●●●●○
HANDLING	●●●●●○
AERO	●●●●●○
COMFORT	●●●●●●
PRICE	●●●●●○

Frame geometry available on page 116

Full specs, bike weights and prices available at wilier.com

NEW

Adlar

BLACK, PURPLE; MATT - COLOR CODE C8



Frame specifications

Frame	CARBON MONOCOQUE NHU MOD - 1190 G ± 5%
Fork	CARBON MONOCOQUE NHU MOD - 470 G ± 5%
Handlebar	STEMMA S / RITCHEY CORRALITOS

LIGHTNESS	●●●●○
HANDLING	●●●●○
AERO	●●●●○
COMFORT	●●●●●
PRICE	●●●●○

Frame geometry available on page 116

Full specs, bike weights and prices available at wilier.com

Jena

PATTERNED BRONZE; GLOSSY - COLOR CODE J18



Frame specifications

Frame	CARBON MONOCOQUE 60TON - 995 G ± 5%
Fork	CARBON MONOCOQUE 60TON - 450 G
Handlebar	STEMMA S / RITCHEY BAR

LIGHTNESS	●●●●○○
HANDLING	●●●●○○
AERO	●●●●○○
COMFORT	●●●●○○
PRICE	●●●●○○

Frame geometry available on page 116

Full specs, bike weights and prices available at wilier.com

Jena

SMOKEY; MATT - COLOR CODE J20

LIGHTNESS	●●●●○○
HANDLING	●●●●○○
AERO	●●●●○○
COMFORT	●●●●○○
PRICE	●●●●○○



Frame	CARBON MONOCOQUE 60TON - 995 G ± 5%
Fork	CARBON MONOCOQUE 60TON - 450 G
Handlebar	STEMMA S / RITCHEY BAR

Frame geometry available on page 116
Full specs, bike weights and prices available at wilier.com



Jaroon

NEW

SAND, GREEN; GLOSSY - COLOR CODE J24

- LIGHTNESS ●●●○○○
- HANDLING ●●●●○○
- AERO ●●●○○○
- COMFORT ●●●●○○
- PRICE ●●●●○○



Frame ALU 6061 - DOUBLE BUTTED THRU-AXLE

Fork CARBON MONOCOQUE THRU-AXLE

Jaroon

NEW

BLUE, GREY; GLOSSY - COLOR CODE J25

- LIGHTNESS ●●●○○○
- HANDLING ●●●●○○
- AERO ●●●○○○
- COMFORT ●●●●○○
- PRICE ●●●●○○



Frame ALU 6061 - DOUBLE BUTTED THRU-AXLE

Fork CARBON MONOCOQUE THRU-AXLE

Jaroon

NEW

GREEN, GREY; GLOSSY - COLOR CODE J26

LIGHTNESS	●●●○○○
HANDLING	●●●●○○
AERO	●●●○○○
COMFORT	●●●●○○
PRICE	●●●●○○



Frame ALU 6061 - DOUBLE BUTTED THRU-AXLE
 Fork CARBON MONOCOQUE THRU-AXLE

Jaroon

NEW

BROWN, LIGHT BLUE; GLOSSY - COLOR CODE J27

LIGHTNESS	●●●○○○
HANDLING	●●●●○○
AERO	●●●○○○
COMFORT	●●●●○○
PRICE	●●●●○○



Frame ALU 6061 - DOUBLE BUTTED THRU-AXLE
 Fork CARBON MONOCOQUE THRU-AXLE

Frame geometry available on page 116
 Full specs, bike weights and prices available at wilier.com

Jareen

NEW

STEEL BLUE, RED, BLACK; GLOSSY - COLOR CODE J23



Frame specifications

Frame ALU 6061 - DOUBLE BUTTED QUICK RELEASE
Fork CARBON MONOCOQUE THRU-AXLE

LIGHTNESS ●●●○○○
HANDLING ●●●●○○
AERO ●●●○○○
COMFORT ●●●●○○
PRICE ●●○○○○

*Frame geometry available on
page 116*

*Full specs, bike weights and
prices available at wilier.com*

Jareen

NEW

BOURDEAUX, GREY, ORANGE; MATT - COLOR CODE J21

- LIGHTNESS ●●●○○○
- HANDLING ●●●●○○
- AERO ●●●○○○
- COMFORT ●●●●○○
- PRICE ●●○○○○



- Frame ALU 6061 - DOUBLE BUTTED QUICK RELEASE
- Fork CARBON MONOCOQUE THRU-AXLE

Jareen

NEW

IRIDE KAKI, BLUE, YELLOW; GLOSSY - COLOR CODE J22

- LIGHTNESS ●●●○○○
- HANDLING ●●●●○○
- AERO ●●●○○○
- COMFORT ●●●●○○
- PRICE ●●○○○○



- Frame ALU 6061 - DOUBLE BUTTED QUICK RELEASE
- Fork CARBON MONOCOQUE THRU-AXLE

Frame geometry available on page 116
 Full specs, bike weights and prices available at wilier.com

ADLAR HYBRID

In developing the new frame platforms, it is now imperative to consider the product in an electric version, applying the basic characteristics to the Hybrid family as well. That's what we did with this version of Adlar with TQ HPR50 motorised pedal assist.





TQ MOTOR

We chose the TQ motor because of its characteristics that make it one of the best central motors in its class. It's super quiet, the lightest of the central motors, with a powerful, but also very smooth and natural thrust.

When we look at the HPR50 motor in detail, we see that it has 50 Nm maximum torque, which is very impressive on a platform weighing 1,850 grams.

We were able to achieve this record weight thanks to the motor's architecture that's completely different from the most common one on the market today. A new design allowed for a very low Q factor, virtually identical to that of the Shimano GRX groupset.

The battery weighs 1,830 grams with 360 Wh capacity.



DISPLAY AND ASSISTANCE

The user interface display, with all system information and connections, is integrated on the frame's top tube.

A very simple button for selecting assistance modes is mounted in a safe and ergonomic position near the handlebar stem. Again, the interface is within finger's reach for greater safety, to ensure riders don't have to take their hand off the handlebars.

RANGE EXTENDER

In addition to the main battery—which can be removed only by a bike repair shop—there will be a range extender with exactly the same measurements as a water bottle that adds 160 Wh of capacity to the system.

SIZES AND HEAD TUBE

Adlar Hybrid is available in five sizes, largely equal to the regular Adlar version, with a slight difference in the head tube, with 69.5° compared to Adlar's 70°.

NEW Adlar Hybrid

MINT GREEN; MATT - COLOR CODE Y24



Frame specifications

Frame	NHU MOD + HIGH IMPACT STRENGTH
Fork	NHU MOD + HIGH IMPACT STRENGTH
Handlebar	STEMMA S / RITCHEY BAR
Motor	TQ HPR50 & HPR50 BATTERY, 360 WH

LIGHTNESS	●●●●○○
HANDLING	●●●●○○
AERO	●●●●○○
COMFORT	●●●●○○
PRICE	●●●●○○

Frame geometry available on page 116

Full specs, bike weights and prices available at wilier.com

NEW

Adlar Hybrid Flat Bar

BLACK, GREY; GLOSSY - COLOR CODE Y23



Frame specifications

Frame	NHU MOD + HIGH IMPACT STRENGTH
Fork	NHU MOD + HIGH IMPACT STRENGTH
Handlebar	STEMMA S / RITCHEY BAR
Motor	TQ HPR50 & HPR50 BATTERY, 360 WH

LIGHTNESS	●●●●○○
HANDLING	●●●●○○
AERO	●●●●○○
COMFORT	●●●●○○
PRICE	●●●●○○

Frame geometry available on
page 116

Full specs, bike weights and
prices available at wilier.com

WILIER TRIESTINA

Jena Hybrid

GREEN, WHITE; MATT - COLOR CODE Y9

- LIGHTNESS ●●●●○○
- HANDLING ●●●●○○
- AERO ●●●●○○
- COMFORT ●●●●○○
- PRICE ●●●●○○



- Frame CARBON MONOCOQUE NH-MOD 1420 G ± 5%
- Fork CARBON MONOCOQUE NH-MOD 450 G ± 5%
- Motor MAHLE X35+ & I250 BATTERY, 242 WH

Jena Hybrid

BLUE, ORANGE; GLOSSY - COLOR CODE Y8

- LIGHTNESS ●●●●○○
- HANDLING ●●●●○○
- AERO ●●●●○○
- COMFORT ●●●●○○
- PRICE ●●●●○○



- Frame CARBON MONOCOQUE NH-MOD 1420 G ± 5%
- Fork CARBON MONOCOQUE NH-MOD 450 G ± 5%
- Motor MAHLE X35+ & I250 BATTERY, 242 WH

88 *Frame geometry available on page 116
Full specs, bike weights and prices available at wilier.com*





MOUNTAIN BIKES



NATURE'S ADRENALIN

Impossible climbs, tricky slopes and unconventional trajectories. Be it the World Cup or in the woods out back, the thrill of the challenge comes from the earth.

URTA MAX SLR MAX! MAX! MAX!



WILIER PIRELLI FACTORY TEAM, CAPE EPIC 2023



Max improvement, Max performance,
Max fun!

This new MTB with 120mm travel has been designed with the aim of providing the Wilier-Pirelli Factory Team a modern and versatile race bike featuring: a high-performance suspension system, precise handling response and safety. From the very first moment, the new Urta Max SLR will make you feel like you are on a bike that is ideal for competitions but also fun on the most demanding trails.



THE NEW SUSPENSION SYSTEM

The Urta Max features a new single-axle damping system.

The compression ratio has been optimised to be extremely effective on any terrain type.

The Rock Shox and Fox rear shock absorbers with 45mm travel that are mounted as standard have compression curves specifically tailored to work in symbiosis with the leverage ratio chosen in the design stage.

There are three operating phases: a regressive phase (stiffer and more sustained); a more reactive and sensitive phase, when maximum efficiency during pedalling is required; and a final phase, that is more progressive, to avoid the suspension reaching the end of its stroke.



FRAME

The two triangles that form the Urta Max SLR frame are made of HUS-MOD high-module carbon fibre, the same used for all top range Wilier products. Maximum stiffness only where necessary.

The front triangle completely integrates the cables within frame, but unlike earlier models - where tubes and sheaths passed through holes made in the carbon fibre - on the Urta Max the brake, derailleur and dropper tubes pass through the headset, similarly to road bikes. This solution provides the bike with an extremely clean and elegant look and, not least, it improves the overall stiffness in the headset area as the absence of holes guarantees continuous modularity and directionality of the carbon fibres.

The rear triangle of the Urta Max is designed with a single-pivot point. The new conrod (stiffened compared to previous versions) is designed to give the frame a maximum travel efficiency of 120mm.

GEOMETRIES

The Urta Max geometries have been designed and optimised to mount a 120mm travel fork, with the aim of keeping the rider in racing position, i.e. dropped and gathered. To do this, we have reduced the stack to a minimum, extending the reach and keeping the bottom bracket lower. It is a solution that allows the rider to stay gathered on the bike, a position that provides better performance. In detail, for size M the stack measures 598 mm and the reach 443 mm, while the steering angle is more open with 67.5° and the seat tube is at a vertical angle of 75°. With these values, the resulting wheelbase (i.e. the distance between the front and rear wheel centres) is greater than the previous Urta model. All this provides the rider with a greater sense of riding safety and aggressiveness in push position. To do this, we have reduced the stack to a minimum, extending the reach and keeping the bottom bracket lower. It is a solution that allows the rider to stay gathered on the bike, a position that provides better performance.





TELESCOPIC SEATPOST AS STANDARD

The Urta Max SLR leaves the Rossano Veneto factory with a 31.6 mm telescopic seatpost. Each size has a telescopic seatpost with dedicated travel: 100 mm travel for sizes S and M; 125 mm travel for sizes L and XL.

DESIGNED FOR MORE MODERN TRANSMISSIONS

The Urta Max SLR has been designed to accommodate the more modern transmissions currently on the market.

It can mount a front crown up to 38 teeth and the standard issue UDH dropout is also compatible with the new Sram Eagle Transmission assemblies.

MAXIMUM FRAME PROTECTION

To protect the rear triangle and its bearings, we have designed a special rubber cover which, when installed in the area where the frame triangles meet, avoids mud, dirt and debris affecting the reliability and life of the frame in the long term.

TYRE CLEARANCE

The rear triangle has a 70 mm clearance point for mounting today's most modern off-road tyres up to 2.4" ideal for any type of cross-country road.

NEW URTA MAX BAR

And finally, for the carbon module there is the new Urta Max Bar monocoque carbon handlebar.

The handlebar is perfectly integrated with the frame - as is the case of road products - thanks to special dedicated spacers. The comfort level is kept high thanks to the material used: the HUS-MOD high-module carbon with its exceptional ability to vertically absorb all the micro-vibrations generated by riding on rough terrains.

The particular negative inclination of the handlebar stem (- 27°) guarantees the rider a gathered position that will enable more powerful pedalling during the push phase, in technical uphill climbing and when relaunching.

NEW

Urta Max SLR

WILIER PIRELLI; GLOSSY - COLOR CODE U10



Frame specifications

Frame	CARBON MONOCOQUE FRAME HUS-MOD + HIGH IMPACT CARBON WEAVE - 1730 G ± 5%
Handlebar	URTA MAX INTEGRATED CARBON BAR - 285 G ± 3%
Travel	120 mm

LIGHTNESS	●●●●●○
HANDLING	●●●●●○
COMFORT	●●●●●○
PRICE	●●●●●●

Frame geometry available on page 116

Full specs, bike weights and prices available at wilier.com

NEW

Urta Max SLR

LIGHT GREY; GLOSSY - COLOR CODE U11



Frame specifications

Frame	CARBON MONOCOQUE FRAME HUS-MOD + HIGH IMPACT CARBON WEAVE - 1730 G ± 5%
Handlebar	URTA MAX INTEGRATED CARBON BAR - 285 G ± 3%
Travel	120 mm

LIGHTNESS	●●●●○
HANDLING	●●●●○
COMFORT	●●●●○
PRICE	●●●●●

Frame geometry available on page 116

Full specs, bike weights and prices available at wilier.com

Urta SLR

RED, BLUE; GLOSSY - COLOR CODE U2



Frame specifications

Frame	CARBON MONOCOQUE FRAME HUS-MOD + HIGH IMPACT CARBON WEAVE - 1730 G ± 5%
Handlebar	URTA INTEGRATED CARBON BAR - 285 G ± 3%
Travel	100 mm

LIGHTNESS	●●●●●●
HANDLING	●●●●●○
COMFORT	●●●●○○
PRICE	●●●●●●

Frame geometry available on page 116

Full specs, bike weights and prices available at wilier.com

Urta SLR

BLACK; MATT - COLOR CODE U1

LIGHTNESS	●●●●●●
HANDLING	●●●●●○
COMFORT	●●●●●○
PRICE	●●●●●●



Frame	CARBON MONOCOQUE FRAME HUS-MOD + HIGH IMPACT CARBON WEAVE - 1730 G ± 5%
Handlebar	URTA INTEGRATED CARBON BAR - 285 G ± 3%
Travel	100 mm

Frame geometry available on page 116
Full specs, bike weights and prices available at wilier.com





USMA SLR

TURN YOUR DAY AROUND!

USMA SLR is the new race-ready hardtail MTB that joins URITA MAX SLR and URITA SLR in the Wilier Triestina top-of-the-range offroad line.

Lightweight, modern, simple, and easy to manage when it comes to mechanical servicing and suspension settings, USMA SLR has been created to meet the specific needs of riders who have forever been demanding an off-road racing bike.



INTEGRATED MONOCOQUE HANDLEBAR

Like its full suspended sisters - URTA MAX SLR and URTA SLR - USMA SLR can be equipped with an integrated monocoque carbon handlebar. Using dedicated spacers, this creates a single module with the rest of the frame to increase comfort and improve the clean look of the cockpit. Cable routing: just two holes on the head tube allow cable routing for the brake, derailleur and the dropper post, integrating them all in the frame.



EXTREME LIGHTNESS

Lightness is one of the two key elements on which the design is based. We know that climbing is hard, and we know how much super-light materials can help in competition and, in general, reduce fatigue. USMA SLR's frame weighs a mere 850 grams, an undeniably exciting platform on which to create super bikes.

SHORT TRIANGLE

To make the bike agile and responsive, we made the rear triangle very short, with a pitch of just 425 mm but with a wheel clearance that fits tires up to 2.4" (60 mm).

PROGRESSIVE GEOMETRIES

USMA SLR features modern and advanced geometries designed on a fork with 100 mm of travel.

FLOW IS FAST

There is a saying that goes "flow is fast". This is what riders will experience while riding USMA SLR. And, if we were to seek a single adjective to define USMA SLR, we would say it's balanced: lightweight and responsive uphill, fast and easy downhill

HUS-MOD CARBON

The carbon technology used for USMA SLR is the same one featured in the high-end road range: HUS-MOD carbon, a combination of superior quality fibers with the addition of highly resistant multi-directional fiber meshes. To keep the stress generated by offroad use under control, the USMA SLR frame has been designed with special focus and care for the tube intersecting points, which have been reinforced.

ANGLES

As for the angles, the 75° seat tube allows riders to adopt the ideal position for constant pushing. Moving to the front, handlebar is tilted at 67.75°. Combining this value with the 430 mm of reach (for a size M) and an increased BB drop, positions the USMA SLR cyclist centered on the bike, with a low center of gravity. This configuration improves the stability in the descents, providing greater safety; both of which are necessary to take on speed when on a downslope.

Usma SLR

BLUE, BLACK; MATT - COLOR CODE U5



Frame specifications

Frame	CARBON MONOCOQUE FRAME HUS-MOD + HIGH IMPACT CARBON WEAVE 860 G ± 5%
Handlebar	URTA INTEGRATED CARBON BAR 285 G ± 5%
Travel	100 mm

LIGHTNESS	●●●●●●
HANDLING	●●●●●○
COMFORT	●●●●○○
PRICE	●●●●●●

Frame geometry available on page 116

Full specs, bike weights and prices available at wilier.com

Usma SLR

BLACK, SILVER; GLOSSY - COLOR CODE U6



Frame specifications

Frame	CARBON MONOCOQUE FRAME HUS-MOD + HIGH IMPACT CARBON WEAVE 860 G ± 5%
Handlebar	URTA INTEGRATED CARBON BAR 285 G ± 5%
Travel	100 mm

LIGHTNESS	●●●●●●
HANDLING	●●●●●○
COMFORT	●●●●○○
PRICE	●●●●●●

Frame geometry available on page 116

Full specs, bike weights and prices available at wilier.com

110 FX

GREY, BLACK, ORANGE; GLOSSY - COLOR CODE H9

LIGHTNESS	●●●●●●●●
HANDLING	●●●●●●○
COMFORT	●●●●●○○
PRICE	●●●●●●●●



Frame CARBON MONOCOQUE 46TON - 1690 G ± 5%

110 FX

BLACK, RED; MATT - COLOR CODE H7

LIGHTNESS	●●●●●●●●
HANDLING	●●●●●●○
COMFORT	●●●●●○○
PRICE	●●●●●●●●



Frame CARBON MONOCOQUE 46TON - 1690 G ± 5%

101X

RED, BLACK; GLOSSY - COLOR CODE X15

- LIGHTNESS ●●●●●●●●
- HANDLING ●●●●●●○
- COMFORT ●●●●●○○
- PRICE ●●●●●●●●

Frame CARBON MONOCOQUE 46TON - 1130 G ± 5%



101X

BLACK, RED, ORANGE; GLOSSY - COLOR CODE X16

- LIGHTNESS ●●●●●●●●
- HANDLING ●●●●●●○
- COMFORT ●●●●●○○
- PRICE ●●●●●●●●

Frame CARBON MONOCOQUE 46TON - 1130 G ± 5%



503X RACE

RED; MATT - COLOR CODE L16

- LIGHTNESS ●●●●●●●●
- HANDLING ●●●●●●○
- COMFORT ●●●●●○○
- PRICE ●●●●●●●●

Frame ALU 6061, THRU-AXLE REAR DROPOUT 12 mm





URTA HYBRID

THE REVOLUTION EVOLVES

Urta Hybrid is Wilier's down-country eMTB with Fazua Ride 60 motor that is taking part of the electric MTB market revolution.

Urta Hybrid is the tangible example of the technological progress achieved thanks to lighter, high-performing materials combined with the most updated electric drive systems. Less than 16 kg for the top-end setup: a record for its category.

Lightness means no need for high-power motors or large-capacity batteries. The Fazua Ride 60 system is the optimal solution for fully preserving the nature and essence of an actual full-suspension carbon MTB: light and fast when climbing; swift, safe and fun on descents. Meanwhile, on the flat, Urta Hybrid's optimised weight provides a smooth ride with easy pedalling, even without assistance, resulting in battery savings and, ultimately, increased range.



MINIMALIST DESIGN, ELECTRIC HEART

Though it may look like a full-suspension down country MTB, the true beating heart of Urta Hybrid is hidden inside it. The new Fazua Ride 60 pedalling assistance system is light, compact, silent and perfectly integrated within the frame.

Thanks to an external auxiliary battery that can be fitted on the down tube (a solution that will still let you carry a bottle on the seat tube), the capacity of the system can be extend up to 640 Wh.

WORLD CHAMPION DNA

When developing Urta Hybrid, the starting point for Wilier's Innovation Lab engineers was the URTA SLR, the full-suspension cross-country bike used by Simone Avondetto, winner of the 2022 XCO U23 World Championship.

Though closely mirroring the racing version, the suspension kinematics in Urta Hybrid have been improved and further developed to meet the needs of an e-downcountry bike.

COMPACT, SAFE, POWERFUL

The 120 mm travel (both front and rear) and the aggressive geometries make Urta Hybrid compact, safe and powerful.

In detail, the geometries feature a longer reach for keeping them centred and tucked within the frame, a 75° seat tube for increased responsiveness in the push stage and a head tube angled at 66.5° for greater manoeuvrability.

MONOCOQUE HANDLEBAR AND CABLE INTEGRATION

Like the Urta SLR version, Urta Hybrid is available with a 760 mm-width Urta Bar monocoque carbon handlebar, in a choice of 3 stem lengths: 60, 75 or 90 mm.

The cables are routed within the frame thanks to two openings on the front of the head tube.

DROPPER SEATPOST

The dropper seatpost KS Ragei is standard and it comes with all Urta Hybrid's set-up.

Urta Hybrid

BLACK, GREY; GLOSSY - COLOR CODE U7



Frame specifications

Frame	CARBON MONOCOQUE NHU-MOD + HIGH IMPACT STRENGTH
Handlebar	URTA INTEGRATED CARBON BAR - 285 G ± 5%
Motor	FAZUA RIDE 60 & ENERGY 430 FIX BATTERY, 430 WH
Travel	120 mm

LIGHTNESS ●●●●●●

HANDLING ●●●●●○

COMFORT ●●●●●○

PRICE ●●●●●●

Frame geometry available on page 116

Full specs, bike weights and prices available at wilier.com

Urta Hybrid

AQUAMARINE; GLOSSY - COLOR CODE U8



Frame specifications

Frame CARBON MONOCOQUE NHU-MOD + HIGH IMPACT STRENGTH

Handlebar URTA INTEGRATED CARBON BAR - 285 G ± 5%

Motor FAZUA RIDE 60 & ENERGY 430 FIX BATTERY, 430 WH

Travel 120 mm

LIGHTNESS ●●●●●●

HANDLING ●●●●●○

COMFORT ●●●●●○

PRICE ●●●●●●

Frame geometry available on
page 116

Full specs, bike weights and
prices available at wilier.com



KARGA

Karga marks Wilier's entry in a new world. Our experience in the MTB world is evolving fast, and Wilier Pirelli's results speak for themselves.

Our philosophy has always led us to design super-light electric bikes for both road and off-road, but we know that most of the market wants different products. With Karga, we addressed this demand head on, completing a project that we are certain will be successful because it responds to the three things that ordinary cyclists typically ask for when buying an MTB bike: lots of motor, lots of battery capacity and lots of travel. Despite these design constraints that are perhaps a bit far from our construction philosophy, we put a touch of Wilier in this design as well.



HIGH-PERFORMANCE KINEMATICS

Despite its 160 mm of travel and over 20 kg in weight, we created high-performance kinematics, clearly for downhill, but also for uphill, to make pedalling easy and pleasant even on steep climbs.

FRAME AND WHEELS

The frame features a carbon monocoque front triangle combined with a double-butt aluminium rear triangle.

The wheels are 29".

SHIMANO MOTOR

The Shimano EP-8 motor is powered by an integrated 720 Wh Simplo battery. The second-generation battery is removable.

BATTERY AND RANGE EXTENDER

Here's an important note about the battery. Although the battery is Simplo brand, it bears a Shimano Service Center sticker because the product will be covered by the Shimano guarantee. So, for service and support, the communication channels will be the usual channels for Shimano products. This is an important point to share with consumers. An external 360 Wh battery will be available in addition to this integrated 720 Wh battery. The system will eventually have a capacity of over 1 kW: 1080 Wh to be precise.

FRAME PROTECTION

As with the Urta series, there will be a special rubber cover to protect the bearings and movements of the link between the rear and front triangles against mud and dirt.

Again on the topic of protecting the frame, Karga will be equipped with a Token brand headset to allow the cables to be integrated inside the frame, and to protect the down tube against sudden impacts with the fork, in case of a fall.

NEW **Karga**

SILVER; GLOSSY - COLOR CODE P13



Frame specifications

Frame CARBON FRONT TRIANGLE + ALU REAR STAYS
MOTOR SHIMANO EP801 +
SIMPLIO BATTERY 720 WH (SHIMANO AFTER SERVICE)

- LIGHTNESS ●●○○○○
- HANDLING ●●●●○○
- COMFORT ●●●●●●
- PRICE ●●●●●○

Frame geometry available on page 116

Full specs, bike weights and prices available at wilier.com

NEW

Karga

BLUE; GLOSSY - COLOR CODE P14

LIGHTNESS	●●○○○○
HANDLING	●●●●○○
COMFORT	●●●●●●
PRICE	●●●●●○



Frame	CARBON FRONT TRIANGLE + ALU REAR STAYS
MOTOR	SHIMANO EP801 +
	SIMPLO BATTERY 720 WH (SHIMANO AFTER SERVICE)

NEW

Karga

GREEN; GLOSSY - COLOR CODE P15

LIGHTNESS	●●○○○○
HANDLING	●●●●○○
COMFORT	●●●●●●
PRICE	●●●●●○



Frame	CARBON FRONT TRIANGLE + ALU REAR STAYS
MOTOR	SHIMANO EP801 +
	SIMPLO BATTERY 720 WH (SHIMANO AFTER SERVICE)

Frame geometry available on page 116
Full specs, bike weights and prices available at wilier.com

O-BAR

SIZE	DESCRIPTION	[mm]	[mm]	[mm]	[mm]	[mm]	[mm]
L	LENGHT (center to center)	90	100	100	110	120	130
W	WIDTH (center to center)	400	400	420	420	430	400
R	REACH	66,5	68,5	68,5	70,5	72	83
D	DROP	123	124,5	124,5	126,5	128,5	138,1

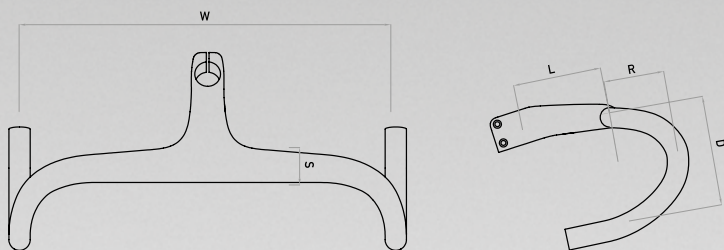

FILANTE BAR

SIZE	DESCRIPTION	1 [mm]	2 [mm]	3 [mm]	4 [mm]	5 [mm]
L	LENGHT (center to center)	88	101	114	127	140
W	WIDTH (center to center)	400	420	420	430	440
R	REACH	68	70	72	74	76
D	DROP	126	128	130	132	134
S	SECTION	41.5	42.5	43.5	44.5	45.5
ALFA	STEM ANGLE	9°	8°	7°	6°	5°

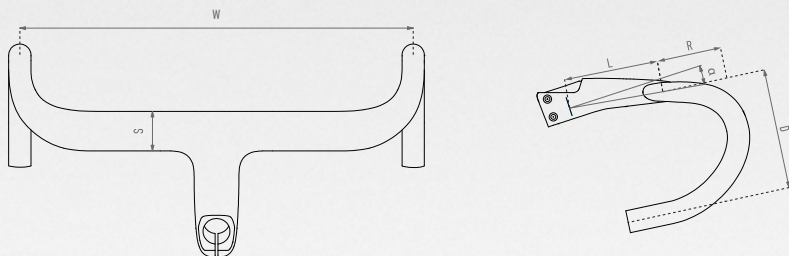

J-BAR

SIZE	DESCRIPTION	(mm)	(mm)	(mm)	(mm)
L	LENGTH (center to center)	95	105	115	125
W	WIDTH (center to center)	430	440	450	460
R	REACH	73	73	73	73
D	DROP	128	128	128	128
S	SECTION	37	38	39	42

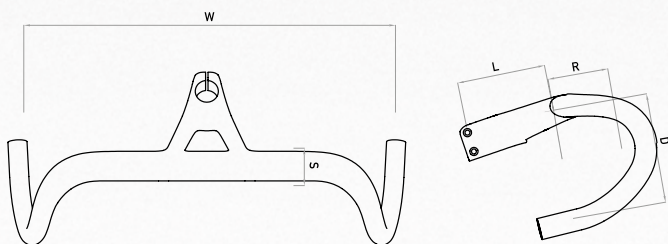

URTA MAX BAR

SIZE	DESCRIPTION	[mm]
L	LENGHT	75
W	WIDTH	760
US	UP SWEEP	4°
BS	BACK SWEEP	8°
ALFA	ANGLE	27°

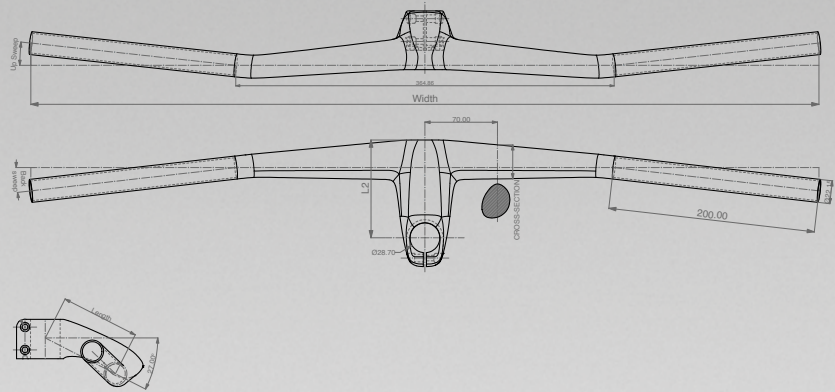

URTA BAR

SIZE	DESCRIPTION	1 [mm]	2 [mm]	3 [mm]
L	LENGHT	60	75	90
W	WIDTH	760	760	760
US	UP SWEEP	4°	4°	4°
BS	BACK SWEEP	8°	8°	8°
ALFA	ANGLE	-17°	-17°	-17°

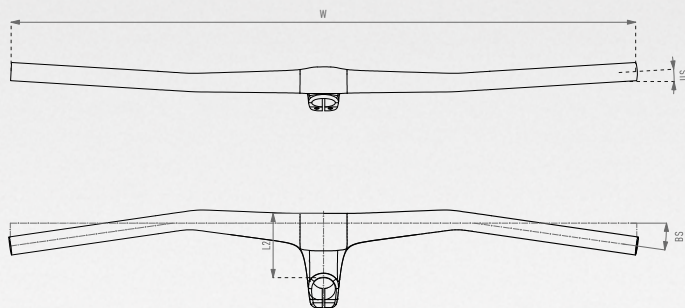

STEMMA SL

SIZE	DESCRIPTION	1 [mm]	2 [mm]	3 [mm]	4 [mm]
L1	LENGHT (center to center)	90	100	110	120
ALFA	Angle of stem	6°	6°	6°	6°
H1	Height of the cable collector	16.5	16.5	16.5	16.5

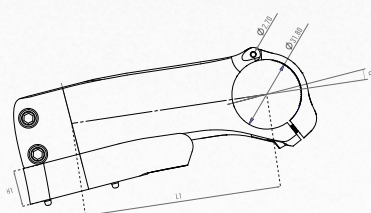

ROAD BIKES



SIZE	REACH (mm)	STACK (mm)	H (cm)	C/C (cm)	L (cm)	A (°)	H1 (cm)	L1 (cm)	A1 (°)	WHEELBASE (mm)
XS	376	503	43	41,2	51,1	75,2	10,2	40,7	70,5	977
S	381	519	46	44,2	52,5	74,6	11,8	40,7	71,7	979
M	386	536	49	47,2	54,1	74	13,6	40,8	72,15	988
L	391	554	52	50,2	55,6	73,5	15,3	41	72,65	996
XL	397	572	54	52,2	57,2	73	17,2	41,1	72,8	1008
XXL	402	591	56	54,2	58,7	72,6	19,2	41,2	73,1	1017

FILIANTE^{SLR}
FILIANTE^{SL}



SIZE	REACH (mm)	STACK (mm)	H (cm)	C/C (cm)	L (cm)	A (°)	H1 (cm)	L1 (cm)	A1 (°)	WHEELBASE (mm)
XS	380	505	45	43,2	51,5	75,2	10,4	40,7	70,8	981
S	384	521	48	46,2	53	74,5	11,9	40,7	72	984
M	388	538	50	48,2	54,3	74	13,5	40,8	72,5	990
L	391	555	52	50,2	55,6	73,5	15,4	41	73	997
XL	395	571	54	52,2	57	73	16,6	41,1	73	1002
XXL	399	587	56	54,2	58,3	72,5	18,1	41,1	73,5	1006

GRANTURISMO^{SLR}



SIZE	REACH (mm)	STACK (mm)	H (cm)	C/C (cm)	L (cm)	A (°)	H1 (cm)	L1 (cm)	A1 (°)	WHEELBASE (mm)
XS	369	527	45	43,8	51,7	74,5	11,7	40,9	71	977
S	374	546	48	46,7	53,2	74	13,6	40,9	71,5	985
M	379	566	50	48,6	54,7	73,5	15,7	41,2	72	995
L	384	586	52	50,5	55,8	73,5	17,7	41,2	72,5	1002
XL	389	604	54	52,4	57,4	73	19,6	41,2	72,5	1013
XXL	395	625	56	54,3	59,2	72,5	21,7	41,4	72,5	1027

Superleggera



SIZE	C/C (cm)	L (cm)	A (°)	H1 (cm)	L1 (cm)	A1 (°)
48	48	51	75	9	40,5	71
50	50	52,5	74,5	10,8	40,5	71,5
52	52	53,5	74,5	12,7	40,5	71,5
53	53	55	74	13,9	40,5	72,5
54	54	55,5	74	14,4	40,5	72,5
55	55	56	74	15,2	40,5	73
56	56	57	73,5	16	40,5	73,5
57	57	58	73,5	16,8	40,5	73,5
58	58	58	73	17,8	40,5	73,5
60	60	60	73	19,8	40,5	73

RIAVE^{SLR}
RIAVE^{SL}



SIZE	REACH (mm)	STACK (mm)	H (cm)	C/C (cm)	L (cm)	A (°)	H1 (cm)	L1 (cm)	A1 (°)	WHEELBASE (mm)
XS	370	513	45	43,2	51	75	9,8	42,1	70	997
S	377	532	48	46,2	52,7	74,5	11,8	42,2	70	1012
M	384	551	50	48,2	54,5	74	13,4	42,3	71	1017
L	391	570	52	50,2	56,1	73,5	15,4	42,3	71	1031
XL	398	589	54	52,2	57,9	73	17,2	42,5	71,5	1041
XXL	405	608	56	54,2	59,7	72,5	18,9	42,7	72	1051

GIARDIA



SIZE	REACH (mm)	STACK (mm)	H (cm)	C/C (cm)	L (cm)	A (°)	H1 (cm)	L1 (cm)	A1 (°)	WHEELBASE (mm)
XS	373	515	44	38,5	51,1	75,2	11,2	40,9	70,5	981
S	378	531	46,5	41	52,6	74,6	12,5	40,9	71,7	981
M	383	548	49	43,5	54,1	74	14,4	41,1	72,15	990
L	388	566	52	46,5	55,6	73,5	16,1	41,1	72,65	996
XL	393	584	55	49,5	58	73	17,9	41,4	72,8	1009
XXL	398	602	58	52,5	60	72,6	19,7	41,4	73,1	1016

ROAD BIKES

Frame Geometries

GTRteam



SIZE	REACH (mm)	STACK (mm)	H (cm)	C/C (cm)	L (cm)	A (°)	H1 (cm)	L1 (cm)	A1 (°)
XS	373	515	45	39,5	51,3	75	11,5	40,6	71
S	378	531	48	42,5	52,7	74,5	13	40,6	71,5
M	383	548	50	44,5	54	74	14,8	40,8	72
L	388	566	52	46,5	55,7	73,5	16,6	40,8	72,5
XL	394	583	55	49,5	57,2	73	18,4	41	72
XXL	399	602	58	52,5	58,9	72,5	20,3	41,1	72,5

TURBINE SLR



SIZE	REACH (mm)	STACK (mm)	H (cm)	C/C (cm)	L (cm)	A (°)	H1 (cm)	L1 (cm)	A1 (°)
XS/S	397	487	50,3	50,1	51,4	76,5	8,2	40,5	72,5
M	418	521	53,8	53,6	54,3	76,5	11,8	40,5	72,5
L/XL	439	555	57,3	57,1	57,2	76,5	15,3	40,5	72,5

FILIANTE
HYBRID



SIZE	REACH (mm)	STACK (mm)	H (cm)	C/C (cm)	L (cm)	A (°)	H1 (cm)	L1 (cm)	A1 (°)	WHEELBASE (mm)
XS	369	527	45	43,8	51,7	74,5	11,7	40,9	71	977
S	374	546	48	46,7	53,2	74	13,6	40,9	71,5	985
M	379	566	50	48,6	54,7	73,5	15,7	41,2	72	995
L	384	586	52	50,5	55,8	73,5	17,7	41,2	72,5	1002
XL	389	604	54	52,4	57,4	73	19,6	41,2	72,5	1013
XXL	395	625	56	54,3	59,2	72,5	21,7	41,4	72,5	1027

GIARDIA
HYBRID



SIZE	REACH (mm)	STACK (mm)	H (cm)	C/C (cm)	L (cm)	A (°)	H1 (cm)	L1 (cm)	A1 (°)
XS	365	515	43	37,5	50,5	75	10,4	40,6	70,5
S	376	532	46	40,5	52,5	74,5	12,1	40,6	71
M	383	555	50	44,5	54,4	74	14,5	40,8	71,5
L	390	576	53	47,5	56,1	73,5	16,6	41	72
XL	395	595	57	51,5	57,8	73	18,5	41,1	72,5

CENTO1HY



SIZE	REACH (mm)	STACK (mm)	H (cm)	C/C (cm)	L (cm)	A (°)	H1 (cm)	L1 (cm)	A1 (°)	WHEELBASE (mm)
XS	365	515	43	37,5	50,5	75	10,4	40,6	70,5	977
S	376	532	46	40,5	52,5	74,5	12,1	40,6	71	985
M	383	555	50	44,5	54,4	74	14,5	40,8	71,5	995
L	390	576	53	47,5	56,1	73,5	16,6	41	72	1002
XL	395	595	57	51,5	57,8	73	18,5	41,1	72,5	1013

E-ROAD BIKES

GRAVEL BIKES

RIAVE^{SLR}
RIAVE^{SL}



SIZE	REACH (mm)	STACK (mm)	H (cm)	C/C (cm)	L (cm)	A (°)	H1 (cm)	L1 (cm)	A1 (°)	WHEELBASE (mm)
XS	370	513	45	43,2	51	75	9,8	42,1	70	997
S	377	532	48	46,2	52,7	74,5	11,8	42,2	70	1012
M	384	551	50	48,2	54,5	74	13,4	42,3	71	1017
L	391	570	52	50,2	56,1	73,5	15,4	42,3	71	1031
XL	398	589	54	52,2	57,9	73	17,2	42,5	71,5	1041
XXL	405	608	56	54,2	59,7	72,5	18,9	42,7	72	1051

AJLAR



SIZE	REACH (mm)	STACK (mm)	H (cm)	C/C (cm)	L (cm)	A (°)	H1 (cm)	L1 (cm)	A1 (°)	WHEELBASE (mm)
XS	395	538	44	38	54,2	75	7,9	42,3	70	1030
S	404	562	47	41	56,2	74,5	10,4	42,3	70	1048
M	413	586	50	44	58,3	74	13	42,3	70	1065
L	422	610	53	47	59,9	74	15,5	42,3	70	1083
XL	431	634	57	51	62,1	73,5	18,1	42,3	70	1101

JENA



SIZE	REACH (mm)	STACK (mm)	H (cm)	C/C (cm)	L (cm)	A (°)	H1 (cm)	L1 (cm)	A1 (°)
XS	363	531	44	38	50,8	75	10	42,3	70
S	372	556	47	41	53,1	74,3	12,5	42,3	70,5
M	382	582	50	44	55,4	73,7	15	42,3	71
L	391	608	53	47	57,7	73,1	17,5	42,3	71,5
XL	401	633	57	51	60	72,6	20	42,3	72

JARON



SIZE	REACH (mm)	STACK (mm)	H (cm)	C/C (cm)	L (cm)	A (°)	H1 (cm)	L1 (cm)	A1 (°)
S	373	555	49	43,5	52,7	74,5	13	44	71
M	380	576	51	45,5	54,5	74	15	44	71,5
L	387	595	53	47,5	56,3	73,5	17	44	71,5
XL	393	614	55	49,5	58,1	73	19	44	71,5

JAREEN



SIZE	REACH (mm)	STACK (mm)	H (cm)	C/C (cm)	L (cm)	A (°)	H1 (cm)	L1 (cm)	A1 (°)
XS	368	524	46	40,5	51,1	75	10	44	70,25
S	376	546	49	43,5	52,9	74,5	12	44	71
M	383	566	51	45,5	54,7	74	14	44	71,5
L	390	585	53	47,5	56,5	73,5	16	44	71,5
XL	396	604	55	49,5	58,2	73	18	44	71,5

GRAVEL BIKES

Frame Geometries

FW

ADLAR
HYBRID



SIZE	REACH (mm)	STACK (mm)	H (cm)	C/C (cm)	L (cm)	A (°)	H1 (cm)	L1 (cm)	A1 (°)	WHEELBASE (mm)
XS	395	538	44	38	54,7	75	10	44,1	69,5	1060
S	404	562	47	41	56,3	74,5	10,6	44,1	69,5	1071
M	413	586	50	44	58,3	74	13,2	44,1	69,5	1089
L	422	610	53	47	59,9	74	15,8	44,1	69,5	1107
XL	431	634	57	51	62,1	73,5	18,3	44,1	69,5	1125

E-GRAVEL BIKES

JENA
HYBRID



SIZE	REACH (mm)	STACK (mm)	H (cm)	C/C (cm)	L (cm)	A (°)	H1 (cm)	L1 (cm)	A1 (°)
S	373	556	47	41	52,9	72,8	12,5	42,3	70,5
M	382	582	50	44	55,3	73,7	15	42,3	71
L	392	608	53	47	57,6	73,1	17,5	42,3	71,5
XL	401	633	57	51	60	72,8	20	42,3	72

MOUNTAIN BIKES

Frame Geometries

URTA^{MAX} SLR



SIZE	REACH (mm)	STACK (mm)	H (cm)	L (cm)	A (°)	H1 (cm)	L1 (cm)	A1 (°)	WHEELBASE (mm)	WHEELSET	TRAVEL (mm)
S	415	598	41	57,5	75	8,8	43,5	67,5	1126	29"	120
M	443	598	44	60,3	75	8,8	43,5	67,5	1154	29"	120
L	471	602	48	63,2	75	9,2	43,5	67,5	1184	29"	120
XL	500	613	52	66,4	75	10,4	43,5	67,5	1218	29"	120

URTA SLR

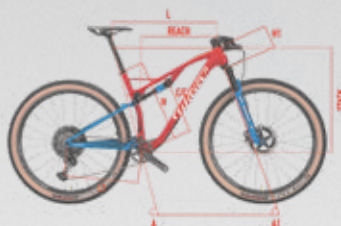

SIZE	REACH (mm)	STACK (mm)	H (cm)	L (cm)	A (°)	H1 (cm)	L1 (cm)	A1 (°)	WHEELBASE (mm)	WHEELSET	TRAVEL (mm)
S	400	593	41	57	74	9	43,5	69	1088	29"	100
M	426	596	44	59,7	74	9,3	43,5	69	1115	29"	100
L	453	604	48	62,6	74	10,1	43,5	69	1145	29"	100
XL	480	613	53	65,6	74	11,1	43,5	69	1175	29"	100

USMA SLR



SIZE	REACH (mm)	STACK (mm)	H (cm)	L (cm)	A (°)	H1 (cm)	L1 (cm)	A1 (°)	WHEELBASE (mm)	WHEELSET	TRAVEL (mm)
S	405	597	40	56,5	75	8,4	42,5	67,75	1090	29"	100
M	430	608	44	59,3	75	9,6	42,5	67,75	1120	29"	100
L	454	619	48	62	75	10,8	42,5	67,75	1148	29"	100
XL	478	630	52	64,7	75	12	42,5	67,75	1177	29"	100

110 FX



SIZE	REACH (mm)	STACK (mm)	H (cm)	L (cm)	A (°)	H1 (cm)	L1 (cm)	A1 (°)	WHEELSET	TRAVEL (mm)
S	395	589	41	57,7	73,5	10	43,8	69,5	29"	100
M	417	596	44	59,4	73,5	10,6	43,8	70	29"	100
L	440	605	48	61,9	73,5	11,5	43,8	70	29"	100
XL	463	614	53	64,5	73,5	12,5	43,8	70	29"	100

MOUNTAIN BIKES

Frame Geometries

104



SIZE	REACH (mm)	STACK (mm)	H (cm)	L (cm)	A (°)	H1 (cm)	L1 (cm)	A1 (°)	WHEELSET	TRAVEL (mm)
S	400	607	42	58	73,5	9,2	43,7	70	29"	100
M	420	610	45	60	73,5	9,3	43,7	70,5	29"	100
L	435	627	49	62,1	73,5	11	43,7	70,5	29"	100
XL	450	644	53	64,7	73	12,9	43,7	70,5	29"	100

503 RACE



SIZE	REACH (mm)	STACK (mm)	H (cm)	C/C (cm)	L (cm)	A (°)	H1 (cm)	L1 (cm)	A1 (°)	WHEELSET	TRAVEL (mm)
S	395	617	42	36	58	73,5	10	44	70,5	29"	100
M	412	628	45	39	60	73,5	11,2	44	70,5	29"	100
L	428	639	49	43	62,5	73	12,4	44	70,5	29"	100
XL	444	650	53	47	65	72,5	13,5	44	70,5	29"	100

URTA
HYBRID



SIZE	REACH (mm)	STACK (mm)	H (cm)	L (cm)	A (°)	H1 (cm)	L1 (cm)	A1 (°)	WHEELBASE (mm)	WHEELSET	TRAVEL (mm)
S	406	593	41	57,6	74	9,3	44,8	66	1148	29"	120
M	432	597	44	60,3	74	9,4	44,8	66,7	1167	29"	120
L	458	608	48	63,2	74	10,5	44,8	66,7	1198	29"	120
XL	485	623	52	66,4	74	12,2	44,8	66,7	1231	29"	120

KARGA



SIZE	REACH (mm)	STACK (mm)	H (cm)	L (cm)	A (°)	H1 (cm)	L1 (cm)	A1 (°)	WHEELBASE (mm)
S	430	620	42	58,5	76,5	10,4	45	64,5	1213
M	455	627	44	61,2	76,5	11,2	45	64,5	1241
L	480	634	46	63,9	76,5	12	45	64,5	1269
XL	505	641	48	66,5	76,5	12,8	45	64,5	1298

HY

E-MTB BIKES

WILIER TRIESTINA SPA

Via Fratel M. Venzo, 11

36028 Rossano Veneto (VI) - Italy

Tel. +39 0424 540 442

info@wilier.it - wilier.com



concept: jonnymole.com

photo: Marco Peruzzo / Different Media Production

Chris Auld - Rouleur.cc - Ourea Production

Ross Bell Photo - Sprint Cycling Agency

print: Grafiche Antiga spa



stampato
con il sole



